

SECTION 303-01C Engine — 6.0L Diesel

CONTENTS

PAGE

IN-VEHICLE REPAIR

Cylinder Head — RH	303-01C-2
--------------------------	-----------

IN-VEHICLE REPAIR**Cylinder Head — RH****Special Tool(s)**

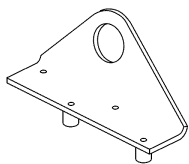
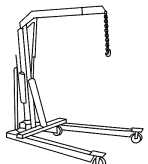
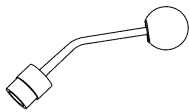
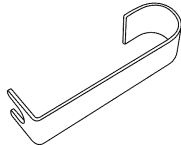
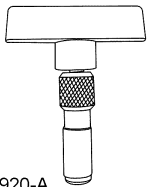
 ST2697-A	Lifting Bracket, Cylinder Head 303-759
 ST1341-A	Heavy Duty Floor Crane 014-00071
 ST2862-A	Release Tool, Injector Connector 303-1115
 ST2861-A	Remover/ Installer, Glow Plug Connector 303-1114
 ST2920-A	Remover, High-Pressure Supply Tube 303-1164

Material

Item	Specification
SAE 15W-40 Super Duty Motor Oil	WSS-M2C171-D

Material(Continued)

Item	Specification
XO-15W40-QSD (US); CXO-15W40-LSD12 (Canada); or equivalent	
High Temperature Nickel Anti-Seize Lubricant XL-2 (US); CXG-2-B (Canada)	ESE-M12A4-A
Metal Brake Parts Cleaner PM-4-A or PM-4-B (US); CPM-4 (Canada)	—

Removal

1. With the vehicle in NEUTRAL, position it on a hoist. For additional information, refer to Section 100-02.
2. Drain the engine oil.
3. Remove the intake manifold. For additional information, refer to Intake Manifold in this section.
4. Remove the evaporator core housing. For additional information refer to Section 412-01.
5. **NOTE:** Only one retainer shown.

Disconnect the wiring harness retainers from the studs.

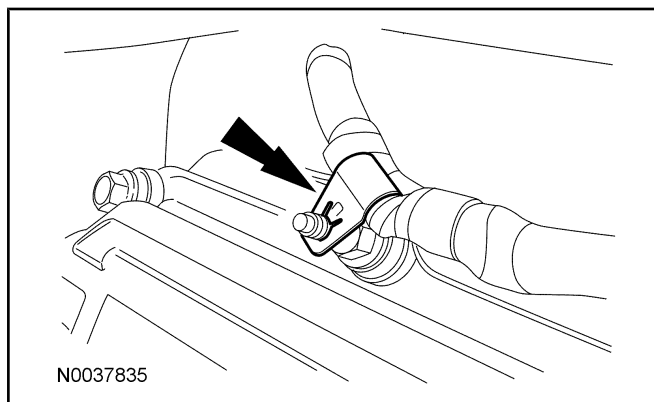

6. Remove the injection control pressure (ICP) sensor.

IN-VEHICLE REPAIR(Continued)

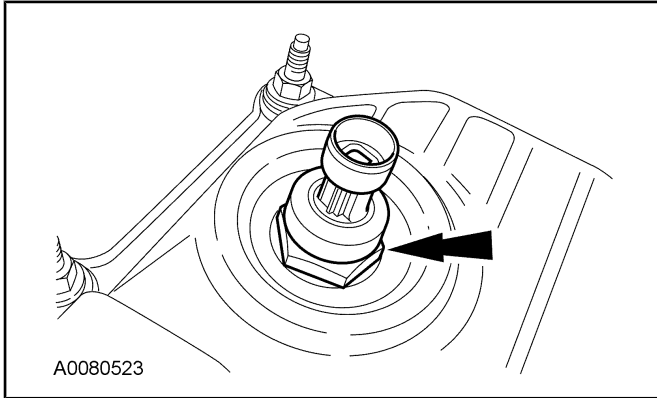

7. If equipped, remove the nut and position the transmission fluid and indicator aside.

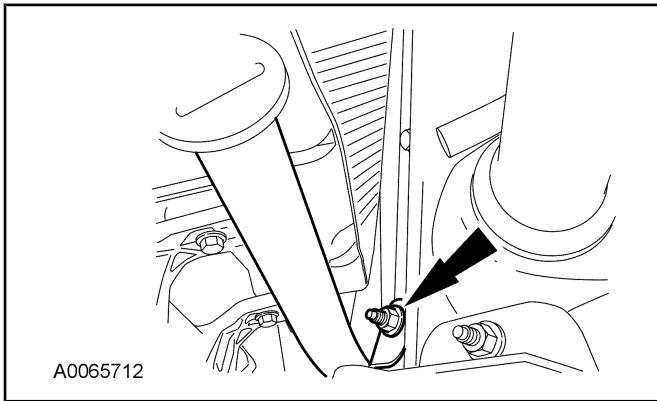

8. **NOTE:** Mark the position of the valve cover bolts for the valve cover bolt installation.

Remove the bolts, stud bolts and the valve cover.

- Clean and inspect the valve cover gasket. Install a new gasket if necessary.

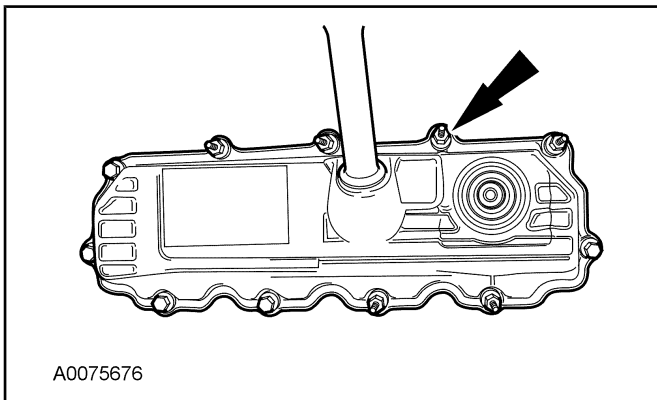

9. Remove the high-pressure oil rail-to-valve cover gasket.

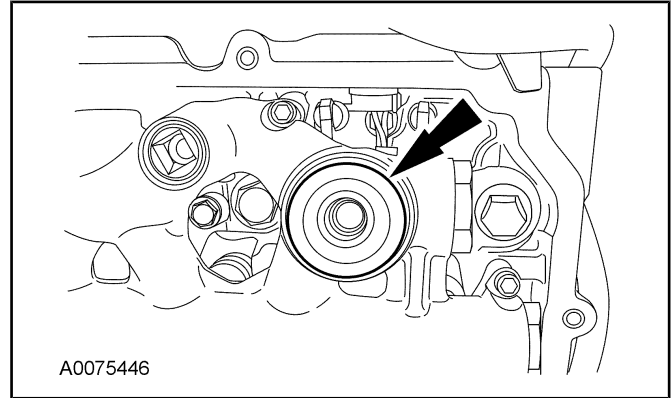

10. Remove the crankcase-to-head tube.

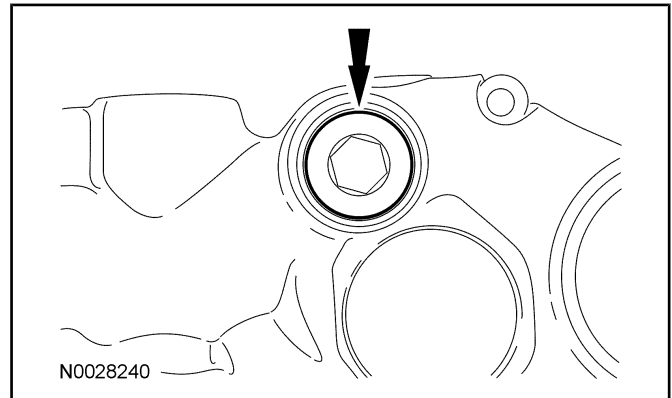

11. **NOTE:** Do not remove the oil rail end plugs or acoustic wave attenuator port fitting. Service parts are not available to support the components.

Remove the bolts and the high-pressure oil rail.

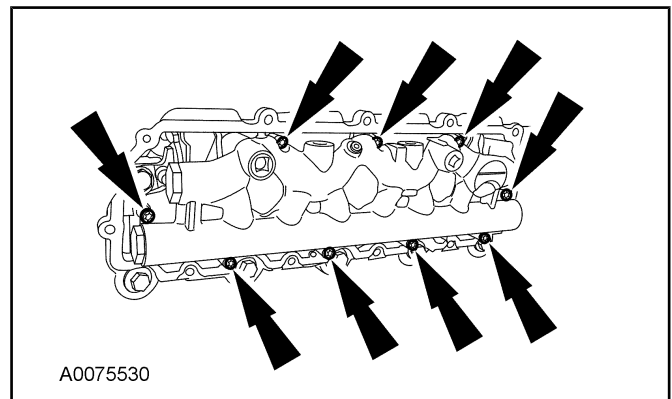

12. **NOTE:** Use a shop towel and metal brake parts cleaner to remove the oil residue prior to removing.

If the crankcase-to-head tube separated, using the special tool, remove the lower crankcase-to-head tube.

IN-VEHICLE REPAIR(Continued)

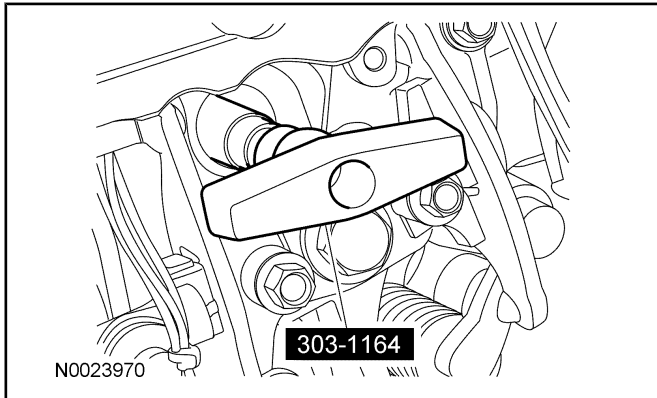

15. **NOTICE:** Do not attempt to apply battery voltage to the fuel injector or damage to the fuel injector will occur.

Using the special tool, push the fuel injector electrical connector out of the rocker arm carrier.

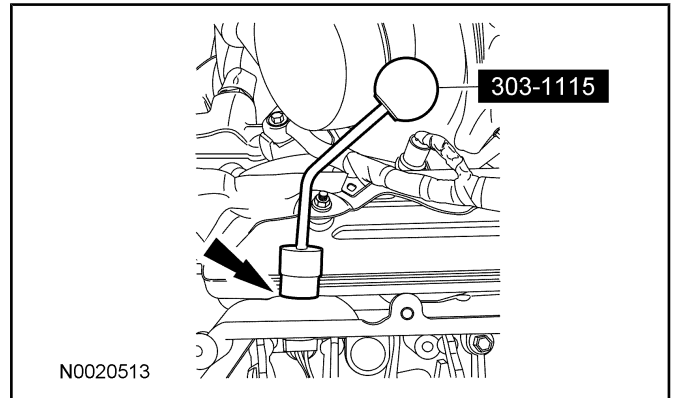

13. Inspect the D-ring seals for damage (nicks, cuts and gouges). If damaged, replace the crankcase-to-head tube.

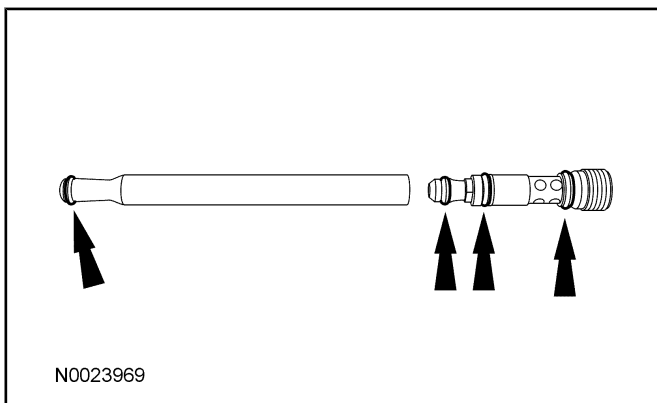

16. Prior to removing the fuel injector assembly, insert clean shop towels in the oil drain holes adjacent to each glow plug.

17. **NOTICE:** Failure to account for all snap rings or pieces prior to placing the vehicle back into service can cause engine damage. A missing snap ring can be ingested into the lube oil system and cause severe engine damage.

NOTICE: To prevent engine damage, do not use air tools to remove the fuel injectors. The snap ring that extracts the injector can dislodge and fall into the oil drain hole.

NOTE: There is no need to drain the fuel rail.

NOTE: If engine coolant is found in the combustion chambers, it may be necessary to install a new injector sleeve. For additional information, refer to Section 303-04C.

NOTE: The bolt is part of the fuel injector hold-down assembly.

Loosen the bolt and remove the bolt and fuel injector hold-down assembly and the fuel injector.

14. **NOTE:** Early build cylinder heads, head gaskets, cylinder block, rocker arm carriers and injector hold-down clamps are not interchangeable with late build engines. It is necessary to identify the head style prior to working on the cylinder heads. Early build heads are equipped with injector hold-down clamps with a square end and a T40 Torx® bolt. Late build heads have injector hold-down clamps with a tapered end and a T45 Torx® bolt.

Determine if the cylinder heads are early build (left frame of illustration) or late build (right frame of illustration).

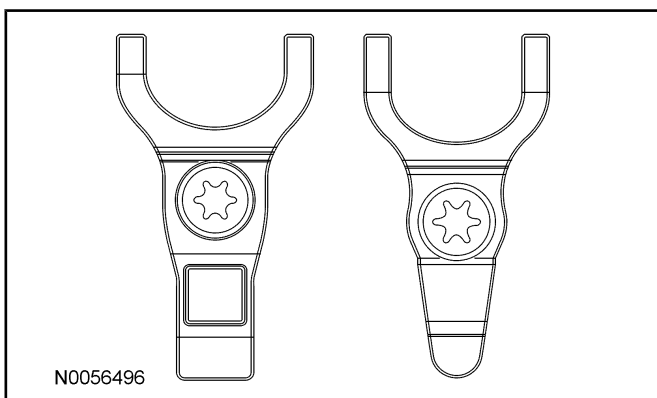

IN-VEHICLE REPAIR(Continued)

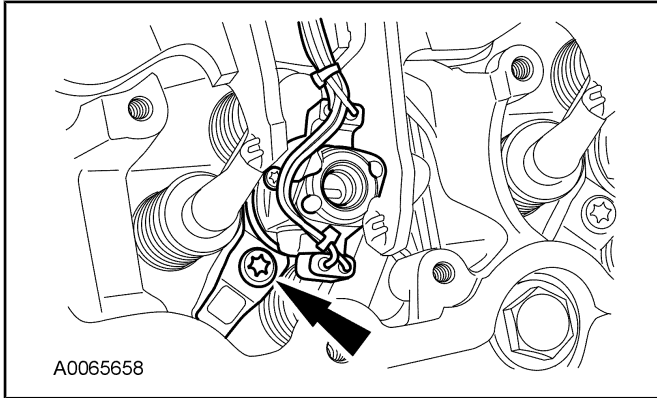

18. **NOTE:** If a snap ring or piece of a snap ring is missing from the injector hold-down assembly, it must be located prior to removing the shop towels.

Remove the shop towels.

19. Remove the starter. For additional information, refer to Section 303-06B.
20. Remove the cylinder block coolant drain plug.

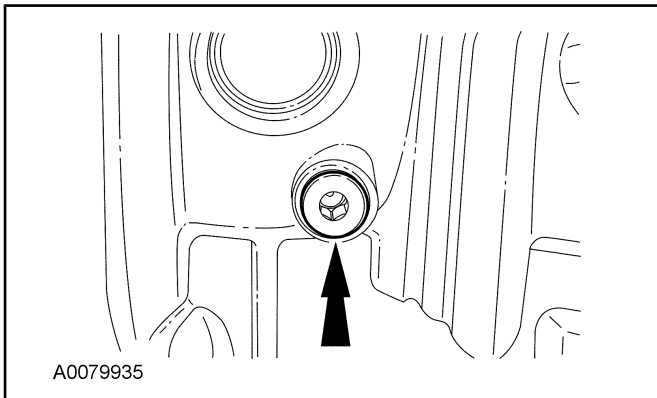

21. **NOTE:** LH shown, RH similar.

Remove the nuts and bolts from the turbocharger adapter pipe.

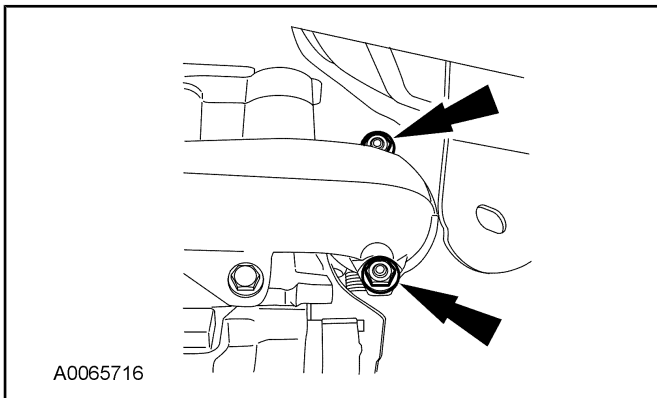

22. Position the turbocharger adapter pipe to gain access to the adapter pipe joint. Remove the bolts, separate the

adapter pipe joint and remove the gasket. Remove the 2 parts of the turbocharger adapter pipe.

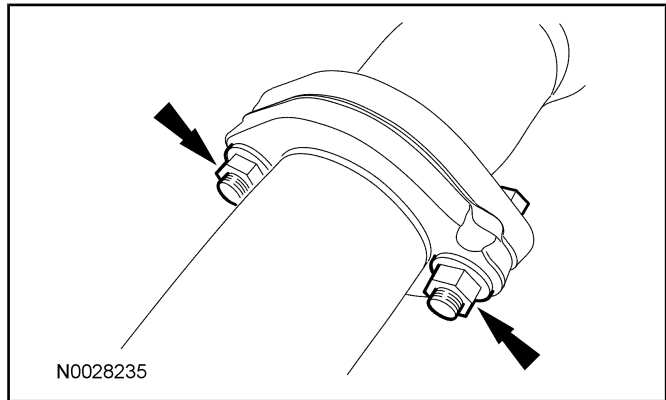

23. **NOTICE:** Do not pull on the wiring to remove the glow plug connector or damage may occur.

NOTE: Only one glow plug connector shown.

Using the special tool, remove the glow plug harness and position aside.

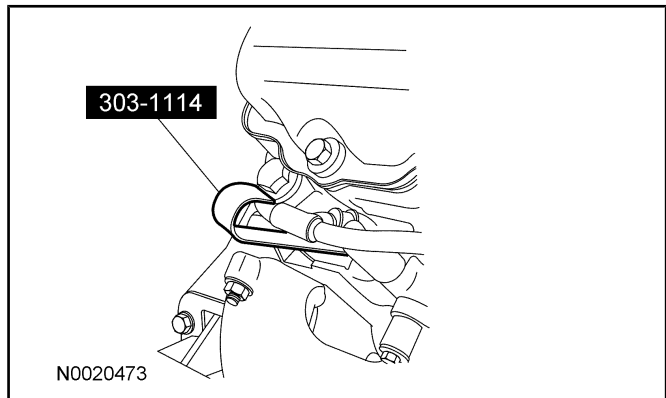

24. Remove the 4 glow plugs.

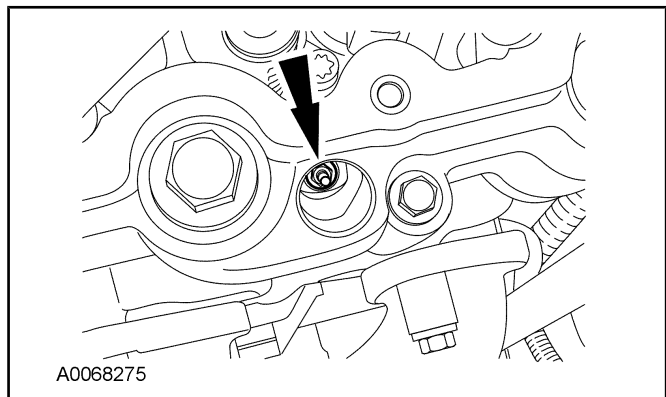

25. Remove and discard the 10 inner cylinder head bolts.

IN-VEHICLE REPAIR(Continued)

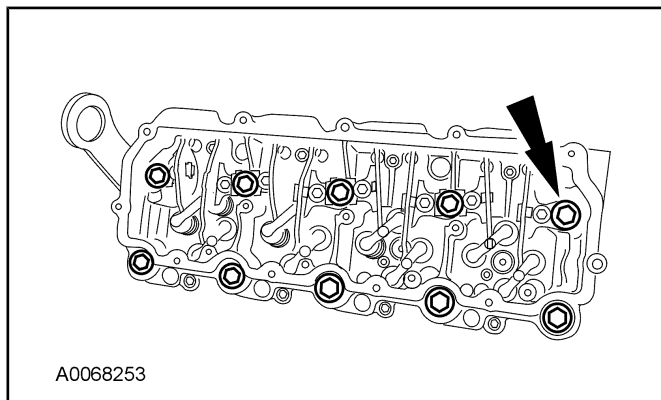

26. Remove the 8 bolts and the rocker arm assemblies.

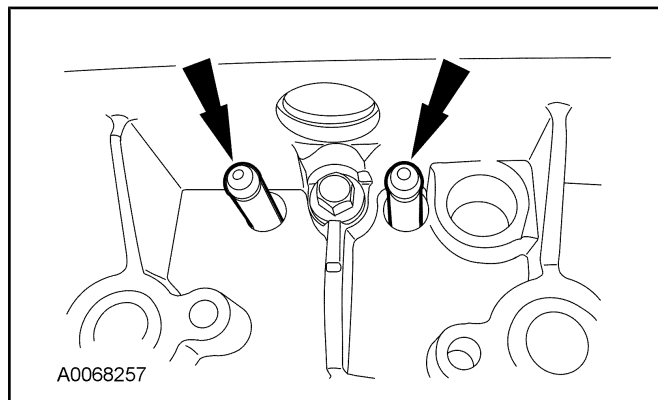

29. Remove the outer cylinder head bolts.

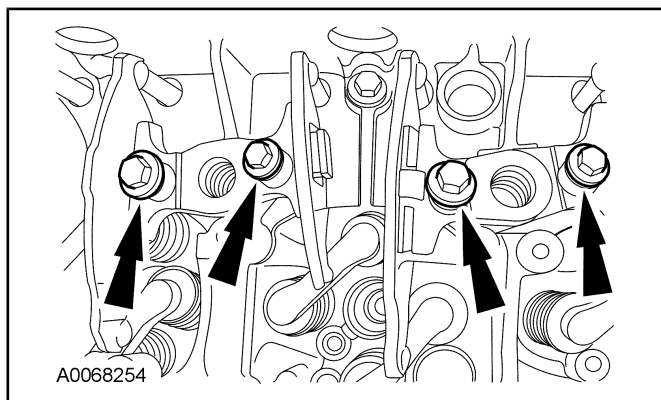

27. Mark the 8 valve bridges with a permanent marker and remove.

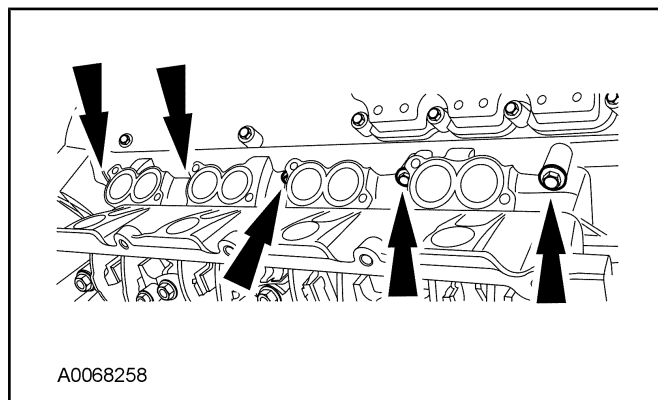

30. Install the special tool and the lifting crane. With the help of an assistant, remove the cylinder head from the vehicle.

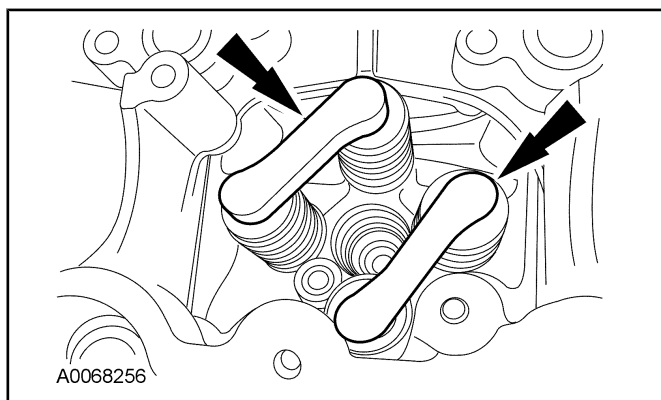

28. **NOTICE:** To prevent engine damage, keep the push rods in the order in which they were removed. Install all push rods back in their original positions.

Mark the location and remove the 8 push rods.

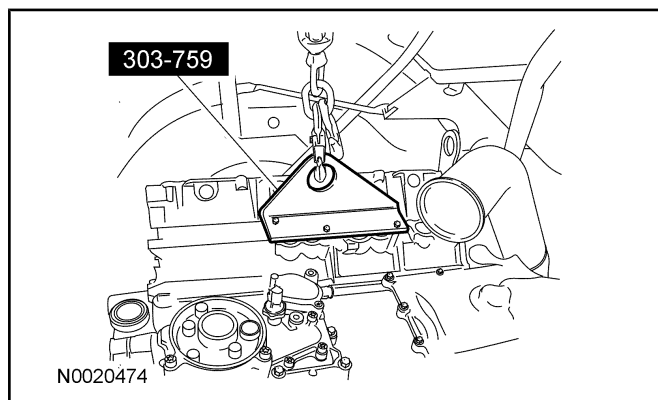

31. Check for cylinder head distortion. For additional information, refer to Cylinder Head Distortion in this section.

32. Remove and discard the cylinder head gasket and dowels.

- Clean and inspect the gasket sealing surfaces.

IN-VEHICLE REPAIR(Continued)

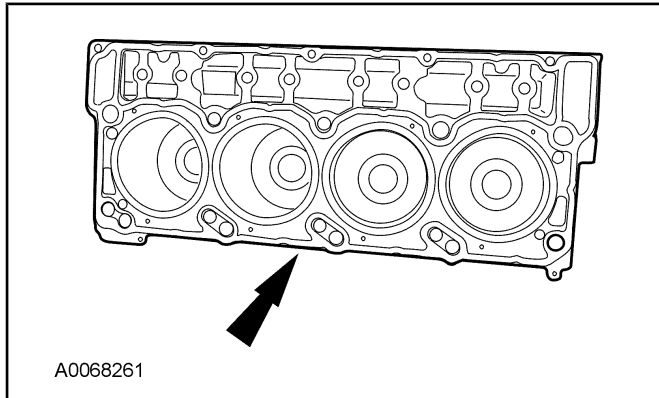

33. Check for cylinder block distortion. For additional information, refer to Cylinder Block Distortion in this section.

Installation

1. **NOTE:** Use care to avoid scratching the blue compound on the cylinder head gasket. Install a new cylinder head gasket with the part number facing up and verify the top 5 holes and the head gasket push rod holes line up.

Install the dowels and the cylinder head gasket.

2. Using the special tools and with the help of an assistant, install the cylinder head on the engine. Remove the special tools.

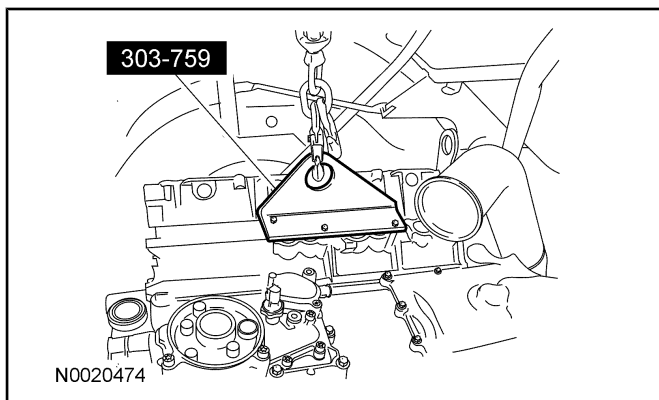

3. Install the outer cylinder head bolts finger-tight.

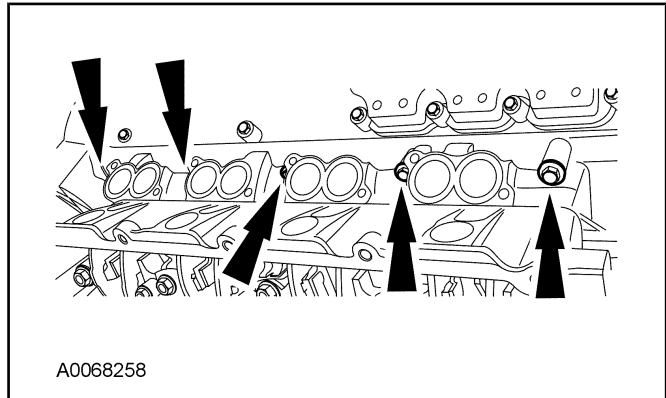

4. **NOTICE:** To prevent engine damage, keep the push rods in the order in which they were removed. Install all push rods back in their original positions.

NOTE: On early build vehicles, higher mileage engines require push rods to be cleaned so the copper-colored end of the push rod can be identified and installed with the copper-colored end up. Push rods on late build vehicles and service push rods do not have a copper-colored end and can be installed with either end up.

Apply clean engine oil to each end of the push rods and insert them into their respective positions.

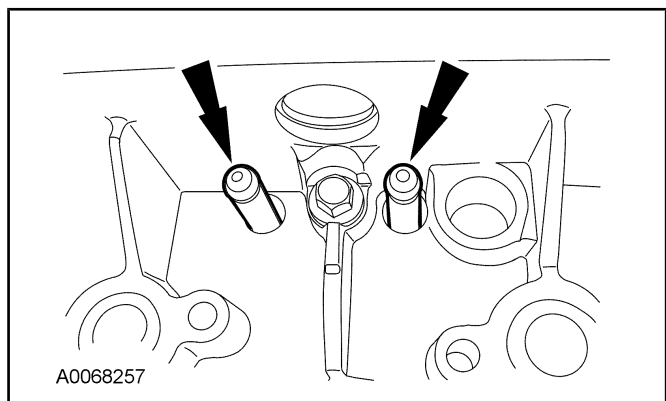

5. **NOTE:** Coat the end of each valve stem with clean engine oil.

Install the 8 valve bridges.

IN-VEHICLE REPAIR(Continued)

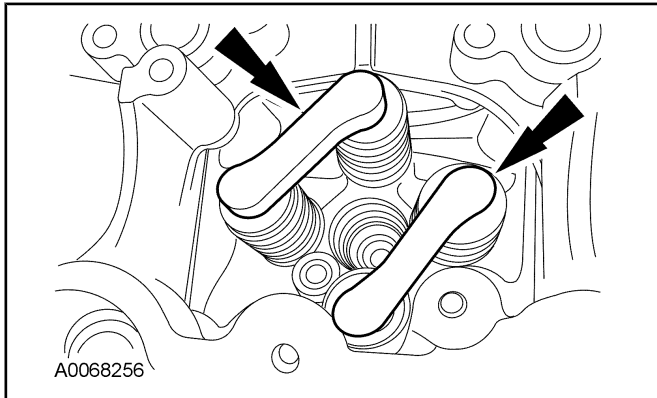

6. **NOTICE:** Rotate the crankshaft until the damper locating dowel notch is in the 6 o'clock position or engine damage can occur.

NOTE: Apply clean engine oil to the top center of each valve bridge.

Install the rocker arm assemblies and the 16 bolts.

- Tighten to 31 Nm (23 lb-ft).

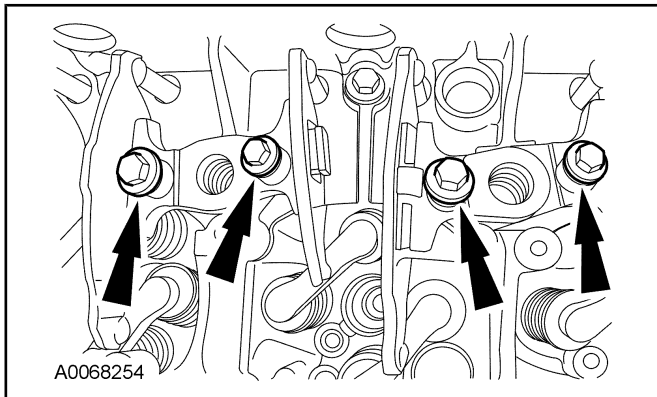

7. **NOTICE:** Using too much engine oil on the threads of the cylinder head bolts can cause damage to the threads and poor sealing. Using anti-seize compounds, grease or any other lubricants other than engine oil on the cylinder head bolt threads can affect the true torque value of the bolts.

NOTE: Lightly lubricate the new cylinder head bolt threads and flanges with clean engine oil.

Install the 10 inner cylinder head retaining bolts finger-tight.

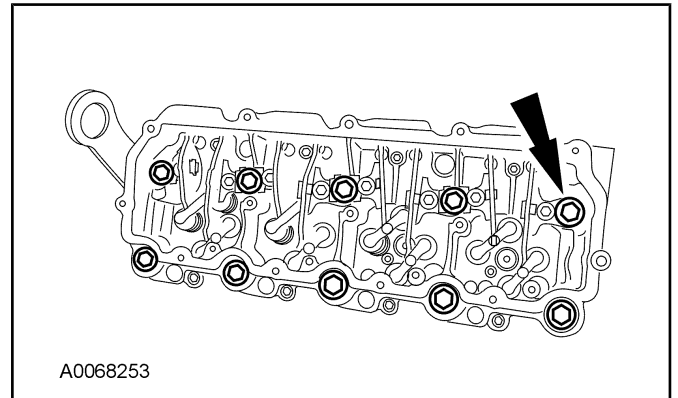

8. Tighten the cylinder head bolts in 7 stages in the following sequence:
- Stage 1: Tighten bolts 1 through 10 to 88 Nm (65 lb-ft).
 - Stage 2: Tighten bolts 1 through 10 to 115 Nm (85 lb-ft).
 - Stage 3: Tighten bolts in sequence 1 through 10, 90 degrees.
 - Stage 4: Tighten bolts in sequence 1 through 10, a second time, 90 degrees.
 - Stage 5: Tighten bolts in sequence 1 through 10, a third time, 90 degrees.
 - Stage 6: Tighten bolts 11 through 15 to 24 Nm (18 lb-ft).
 - Stage 7: Tighten bolts 11 through 15 to 31 Nm (23 lb-ft).

IN-VEHICLE REPAIR(Continued)

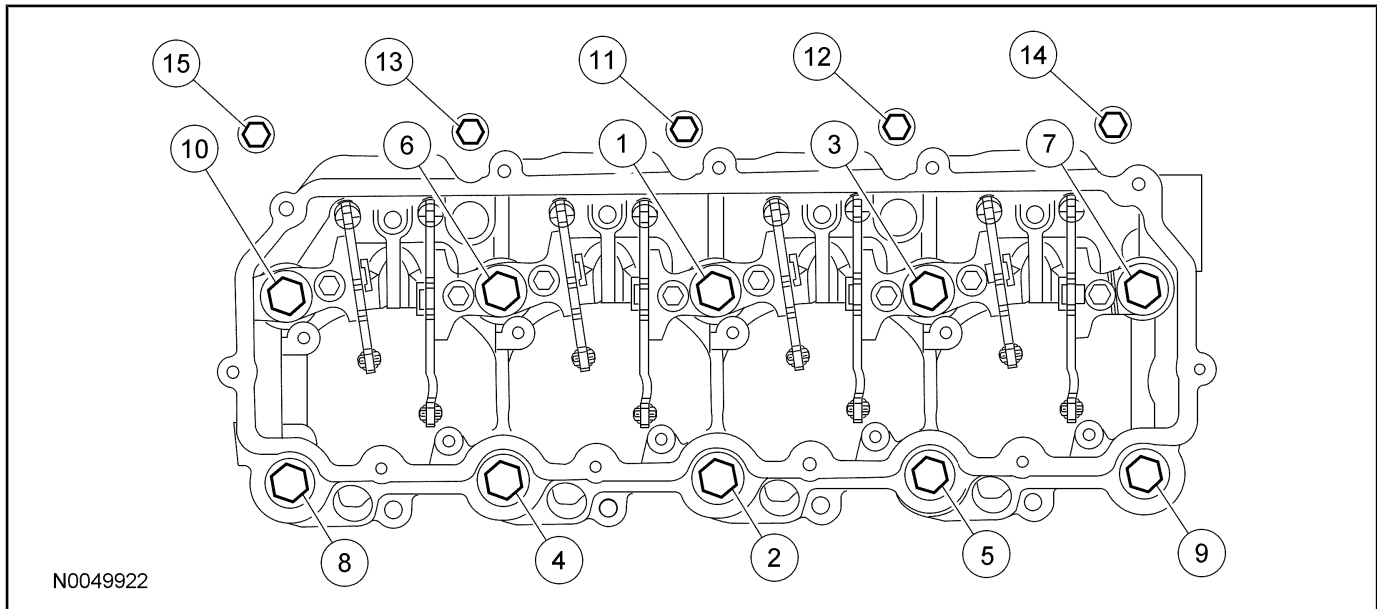

9. Install the 4 glow plugs.

- Tighten to 19 Nm (14 lb-ft).

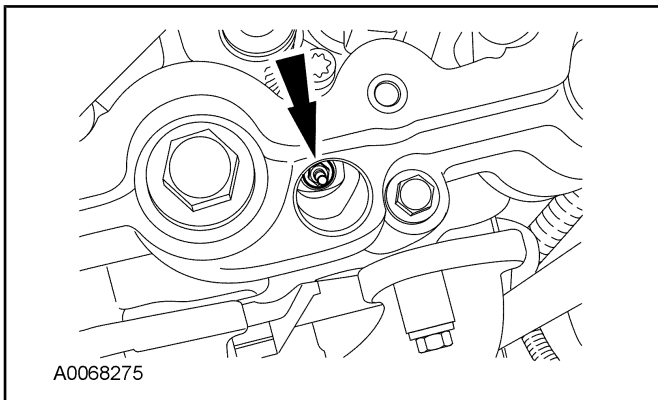

10. **NOTE:** Clean and apply clean engine oil to the O-ring seals.

Using the special tool, install the glow plug harness.

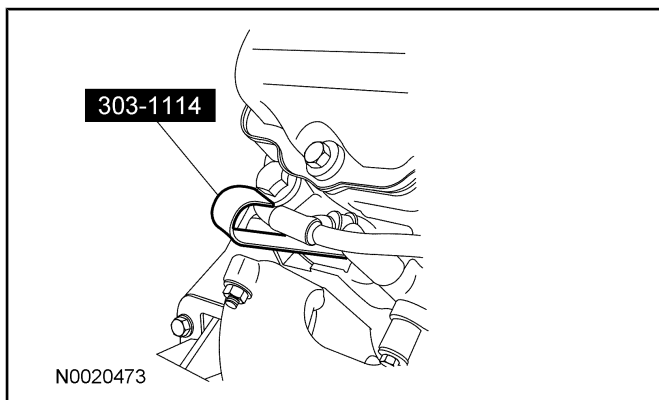

11. Position the 2 parts of the turbocharger adapter pipe into the vehicle. Install the gasket, connect the adapter

pipe joint and install the bolts. Position the turbocharger adapter pipe on the exhaust manifolds.

- Tighten to 27 Nm (20 lb-ft).

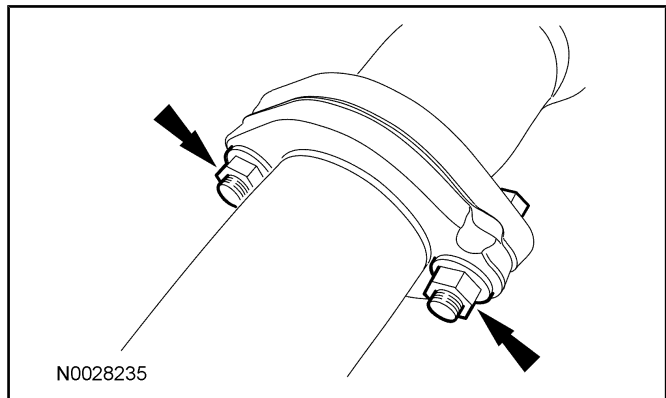

12. **NOTE:** Apply anti-seize lubricants to the bolt threads prior to installing the bolts.

NOTE: Do not tighten until after the turbocharger is installed.

Install the nuts and bolts in the adapter pipe.

- Tighten to 27 Nm (20 lb-ft).

IN-VEHICLE REPAIR(Continued)

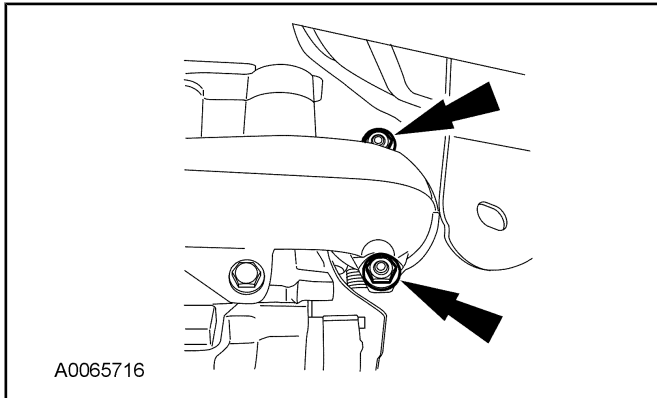

13. **NOTE:** Apply clean engine oil to the O-ring seal prior to installing.

Install the cylinder block coolant drain plug.

- Tighten to 20 Nm (15 lb-ft).

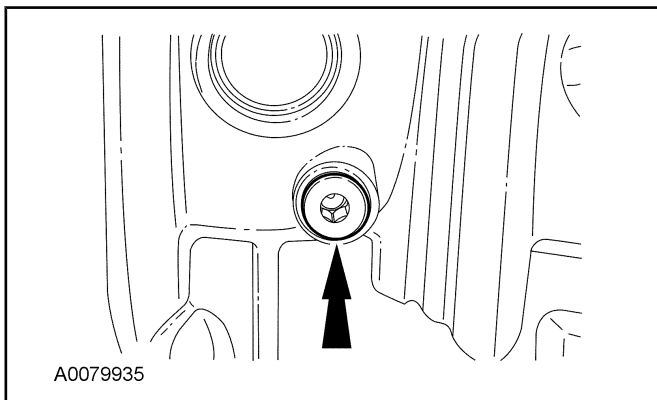

14. Install the starter. For additional information, refer to Section 303-06B.
15. **NOTICE:** If the fuel injector oil inlet D-shaped O-ring seal is damaged, a new fuel injector must be installed.

Install new O-ring seals and copper washer on the fuel injector. Lubricate the fuel injector and O-ring seals liberally with clean engine oil.

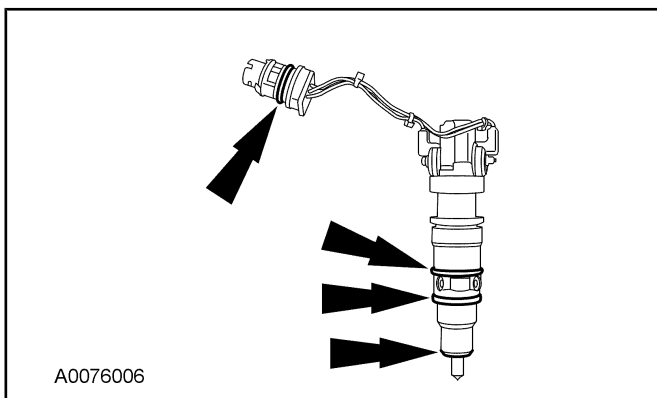

16. **NOTICE:** Failure to tighten the injector properly can lead to engine failure.

NOTICE: To prevent engine damage, do not use air tools to install the fuel injectors. The snap ring that extracts the injector can dislodge and fall into the oil drain hole.

Assemble the fuel injector hold-down and bolt on the fuel injector and install the assembly.

- Early build vehicles (T40 Torx®), tighten to 33 Nm (24 lb-ft).
- Late build vehicles (T45 Torx®), tighten to 35 Nm (26 lb-ft).

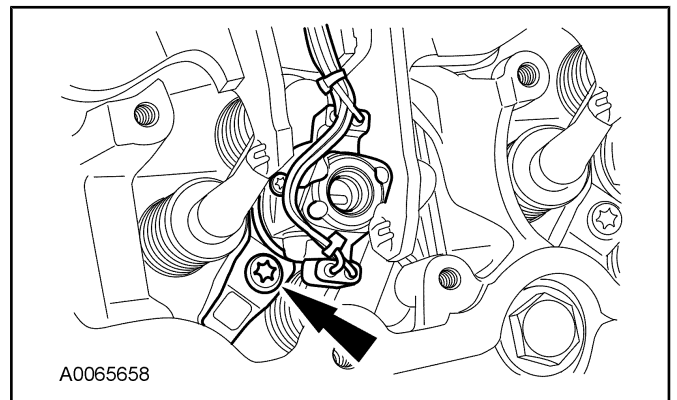

17. **NOTICE:** Make sure the injector wiring is clear of all moving parts or engine damage can occur.

Install the fuel injector electrical connector into the rocker arm carrier.

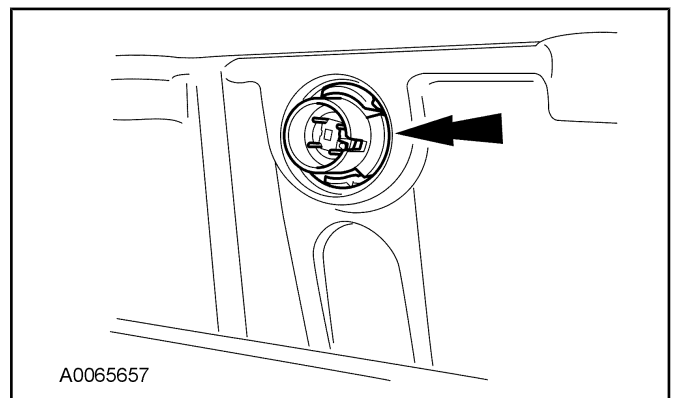

18. Apply engine oil to the top fuel injector O-ring seals.

IN-VEHICLE REPAIR(Continued)

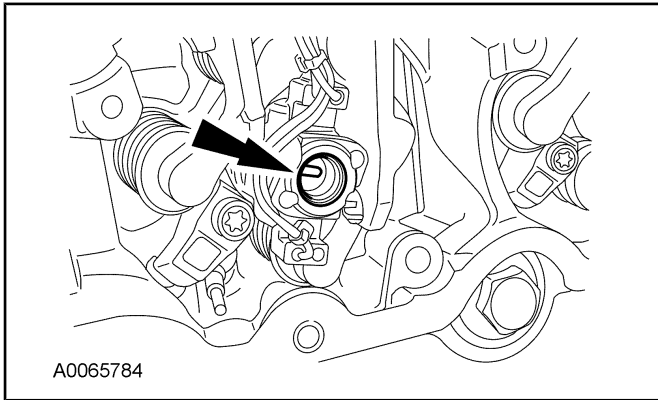

19. **NOTICE:** Using the bolts to push the high-pressure oil rail into the fuel injectors can damage the fuel injectors and high-pressure oil rail.

NOTE: Apply clean engine oil on the tubes prior to installing the high-pressure oil rail.

Position the oil rail on the fuel injectors.

- Place the oil rail on top of the carrier so that the 4 single ball tubes are engaging the injector lead angle.
- Insert 3 guide bolts, 2 on the ends of the straight side of the oil rail and 1 in the middle of the wavy side of the rail. Install the guide studs 6 to 7 turns.
- Manually press the oil rail into the fuel injectors.
- Make sure that the oil rail mounting feet are flat against the mounting surface.
- Loosely install the 6 bolts.

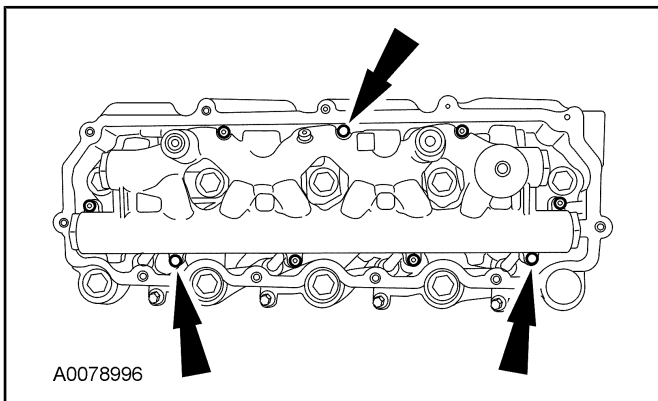

20. Remove the 3 guide bolts, install the remaining bolts and tighten the 9 bolts in the sequence shown.
- Tighten to 13 Nm (10 lb-ft).

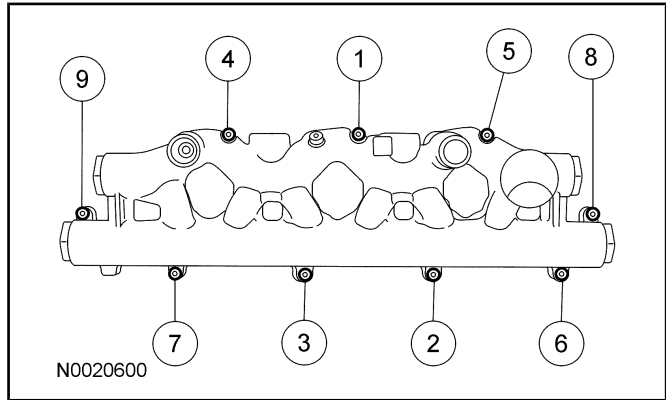

21. Apply clean engine oil to the D-ring seals and reassemble the crankcase-to-head tube if necessary. Install the crankcase-to-head tube.
- Tighten to 82 Nm (60 lb-ft).

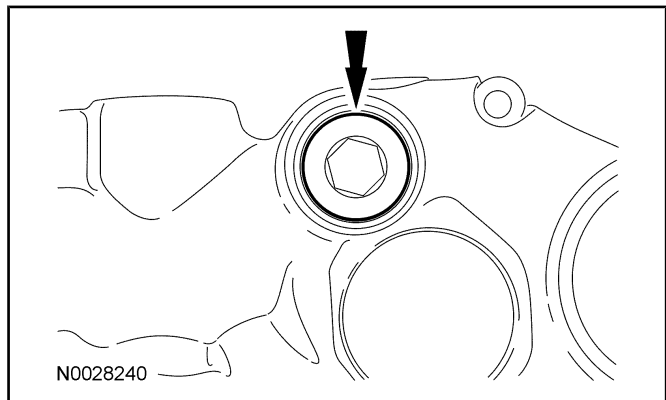

22. Install the high-pressure oil rail-to-valve cover gasket.

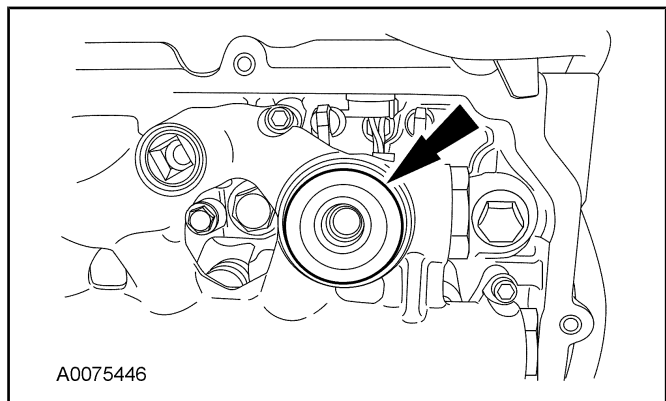

23. **NOTICE:** To prevent engine damage, do not use air-powered tools when installing the valve cover.

Position the valve cover gasket. Install the valve cover and 11 bolts.

- Tighten to 9 Nm (80 lb-in).

IN-VEHICLE REPAIR(Continued)

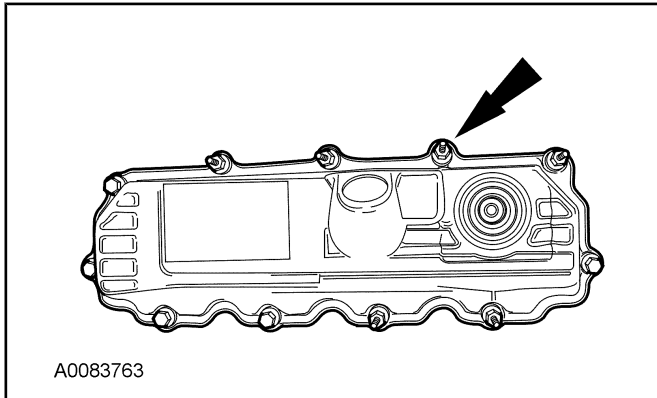

24. If equipped, position back the transmission fluid indicator and tube. Install the retaining nut.

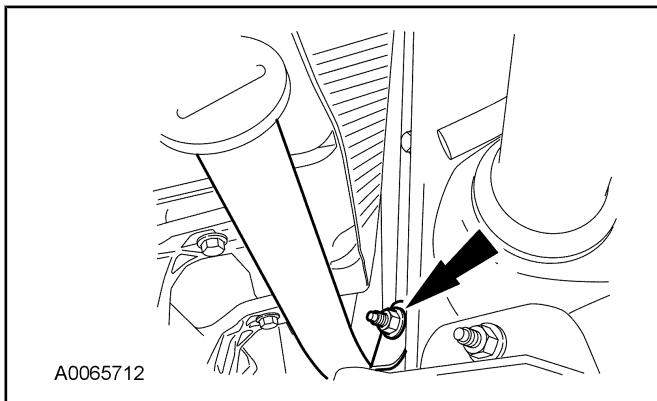

25. Install the ICP sensor.
- Tighten to 12 Nm (9 lb-ft).

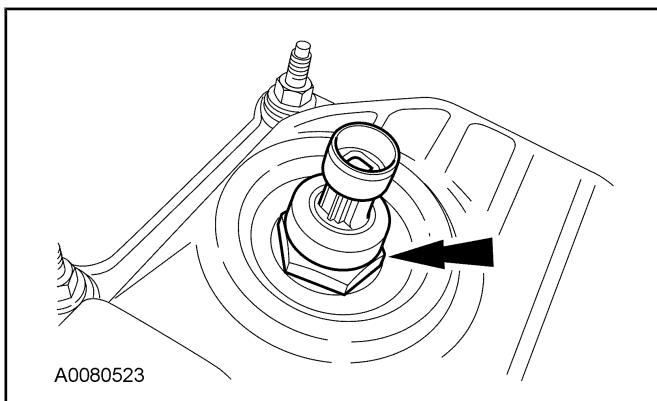

26. **NOTE:** Only one retainer shown.

Connect the wiring retainers to the studs.

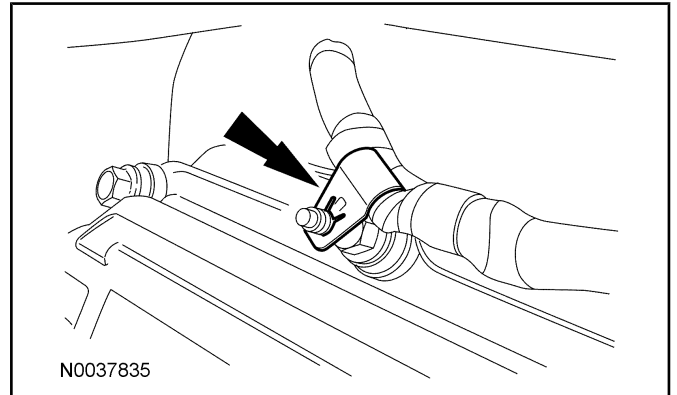

27. Install the evaporator core housing. For additional information, refer to Section 412-01.
28. Install the intake manifold. For additional information, refer to Intake Manifold in this section.
29. **NOTE:** Install a new oil filter.

Fill the crankcase with clean engine oil.